GERÄTEDOKUMENTATION

Miteinander zum Erfolg



VARSEO S Basic

VARSEO S Partner

DOC 86087-en / 02

en



VARSEO S Basic
38200100
VARSEO S Partner
38700100

TRANSLATION OF THE ORIGINAL OPERATING INSTRUCTIONS

VARSEO S Basic VARSEO S Partner

en English



VARSEO S Basic
VARSEO S Partner

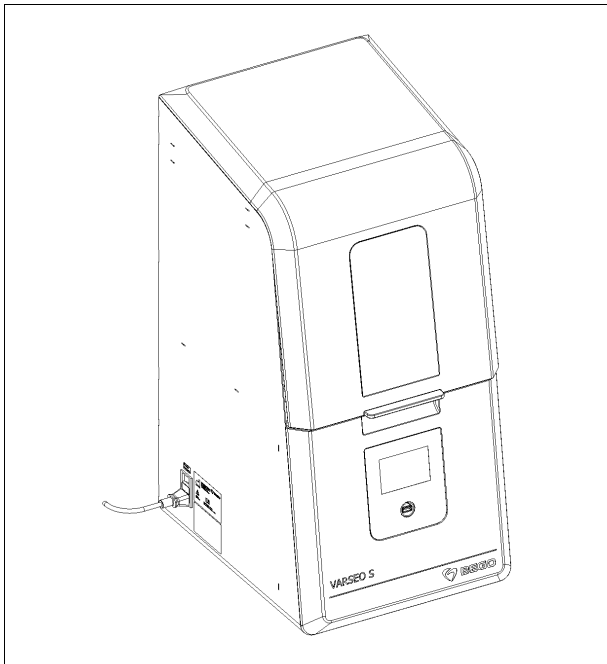



- The device has been designed solely for use in dental laboratories and comparable institutions for research, commercial and training purposes. The device must only be operated by dental professionals; trainees and other persons operating the device must be supervised.
- The operating instructions must be read and understood before the device is used. This applies, in particular, to **Safety Instructions**. Damages caused by failure to observe these operating instructions will invalidate any and all warranty claims. We will also not accept liability for any resulting consequential damages.
- Symbols used

Table of contents

General Information	3
Warranty and Liability	5
Unpacking / Packing	6
Safety instructions	7
Device description	10
Scope of delivery and accessories	12
Varseo S Services	13
Technical data	14
Installation	14
Basic principles	15
Initial commissioning	16
Filling the VARSEO S cartridge	20
Interface to the CAMbridge software	21
Machine data export	22
The initial print job with a test file	23
Operation – Device hardware	25
Operation via Web Interface	33
Service and Maintenance	36
Troubleshooting	41
Signs, labels and stickers	43
Disposal	44
Declaration of Conformity	Appendix

This device documentation is part of the device and must be enclosed when selling or passing on the device.

 This symbol indicates very important information. Failure to comply with it may result in personal injury.

 Warning of optical radiation

 Warning of a risk of crushing

 ATTENTION (see safety data sheets)

 Hazard symbol Environmental hazard

 Use eye protection (protective glasses against mechanical hazards).

 This symbol indicates that safety gloves have to be worn.
Recommendation: Nitrile gloves

 This symbol indicates that protective clothing must be worn.

 Read the operating instructions carefully.

 Protect from direct light / sun light.

 Protective ground terminal: Identification mark

General Information

Importance of the operating Instructions

These operating instructions cover all the information that is necessary according to the relevant regulations for the safe operation of the device described herein.

The operating instructions are a part of the device. The operating instructions should therefore

- always be kept at hand near the device until the device is disposed of,
- and should be passed on with the device when it is sold, transferred or rented/leased out.

Contact the manufacturer if you are unsure about anything in the operating instructions.

We welcome any suggestions or contributions; please feel free to contact us. Your effort will help us make the operating instructions more user-friendly and respond more effectively to your needs and requirements.

Target group

This document is directed toward everyone who works with this device or performs service tasks that are described in this document.

Contact information

BEGO Bremer Goldschlägerei Wilh. Herbst GmbH & Co. KG

Wilhelm-Herbst-Str. 1

28359 Bremen • Germany

Phone: +49 421 2028-0

Service-Hotline Phone: +49 421 2028-270

www.bego.com

© Copyright by BEGO Bremer Goldschlägerei Wilh. Herbst GmbH & Co. KG

These operating instructions are protected by copyright. All rights reserved.

No part of this document may be reproduced without the express written permission of BEGO Bremer Goldschlägerei Wilh. Herbst GmbH & Co. KG!

Conventions

These operating instructions contain references to residual hazards, important user tips and handling instructions that are identified with the following symbols and words.

DANGER

This reference identifies hazards that can cause serious bodily injury or death if the relevant hazard instructions are not followed or not followed properly.

WARNING

This reference identifies hazards that can cause bodily injury or property damage if the relevant hazard instructions are not followed or not followed properly.

CAUTION

This reference identifies only those hazards that are potential damaging to property and the environment.

NOTE

This symbol identifies user tips and particularly useful information. It helps you optimally exploit all the functions of your machine.

1. Sequential actions are described in sequentially numbered paragraphs.
- Cross-references are identified with this symbol.

Warranty and Liability

Our "General terms and conditions of sale and delivery" apply. These terms and conditions are available to the operator since the conclusion of the contract at the latest. Warranty and liability claims for personal injury and property damage are excluded if these are attributable to one or more of the following causes:

- Improper use of the device;
- Improper installation, commissioning, operating and maintenance of the device;
- Operating the device with safety installations/safeguards that are defective, improperly installed or inoperable;

- Failure to observe the notes contained in these operating instructions regarding the transport, storage, installation, commissioning, operation, service and maintenance of this device;
- Unauthorized structural modifications to this device;
- Inadequate monitoring/inspection of device parts that are subject to wear;
- Improperly performed repairs;
- Disastrous situations/emergencies caused by foreign objects or force majeure.

Intended use

This 3-D printer is solely designed for the manufacture of medical technical objects.

The use of the device for any other purpose such as, for example, the production of weapons or other dangerous objects, as well as to produce objects that are protected by copyright is strictly prohibited.

Any use deviating from the specified use is deemed improper use and is strictly prohibited.

Prohibited are:

- the use of the device if it is not in perfect condition or in case of safety-relevant device malfunctions,

- any operation without protective covers or protective equipment/safeguards,
- working with the device without wearing protective clothing,
- unauthorized modification on the machine,
- the assignment of unqualified personnel.

The manufacturer has no knowledge of any improper use up to this time.

Exclusion of liability in case of modifications

If a modification by the user affects any aspect of the performance data or intended functioning, as described in the relevant standards of the 3-D printer, the person or organization that undertook

the modification is responsible for obtaining a new classification and new labelling for the 3-D printer. This person or organization then assumes the status of "manufacturer".

Exclusion of liability for the CAMbridge dongle

The owner is liable for the loss of the CAMbridge dongle

Unpacking / Packing

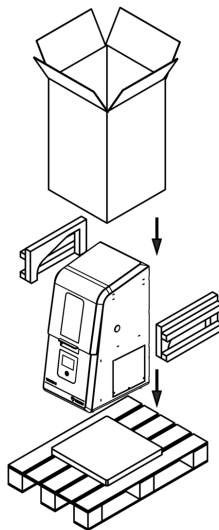
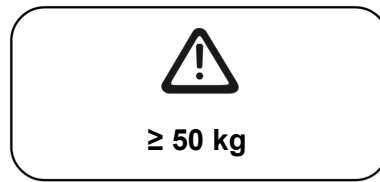
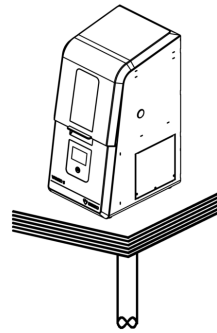
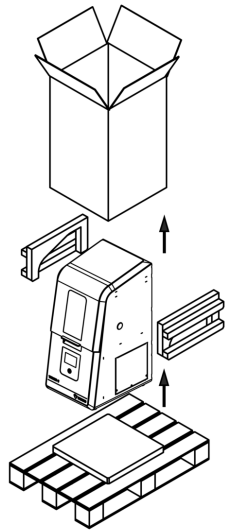

REF 20356

Safety instructions

The 3D print system BEGO VARSEO S is based on DLP technology (Digital Light Processing); it is intended solely for dental applications to create objects from stereo lithography resins, which have been approved by BEGO. Any other use is considered to be improper. We shall not be liable for any damage resulting from improper use.

The safety instructions must be followed in order to prevent personal injury and damage to the machine.

General safety instructions

Place where effective - The device has been designed solely for use in dental laboratories and comparable establishments for research, commercial and training purposes.

The device may only be installed on a sufficiently stable surface. The height of the table should not exceed 720 mm to avoid posture problems.

The device should only be used in **dry, dust free and well ventilated** rooms.

Operator and operating personnel - The device must only be operated by dental professionals; trainees and other persons operating the device must be supervised.

Wear the protective clothing prescribed for use in dental laboratories and observe the rules of conduct.

The device may only be operated by staff members who are familiar with and follow the instructions of this operating manual.

The operating manual must be easily accessible when the machine is operated. Observe the national accident prevention regulations in addition to this operating manual.

Handling the machine - Check if the specifications on the type plate correspond to the power supply network before connecting the device. Consult an electrician in case of uncertainty.

The device is categorised under protection class I and may only be connected to properly earthed power sources (earth contact sockets).

Modifications of the machine are not permitted.

Always keep signs and stickers such that they are easy to read. They must not be removed.

We shall not be liable for damage due to failure to comply with the safety instructions.

WARNING



Risk of injury!

Observe the safety data for the resin used!

Check the machine and leads for damage regularly. The machine must not be operated if it has any defects that may result in risks for the employees or third persons.

The operation of the device requires a LAN or WLAN connection, which must be set up beforehand!

Protect the leads against heat, oil and sharp edges. The leads must not be used to carry the machine or to pull out the mains plug.

Repair work - Repairs may be carried out solely by BEGO customer service personnel or by persons authorized by the BEGO customer service department.

Metallic housings must be grounded properly so as to prevent them from carrying current. Otherwise they are extremely dangerous because the housings may be live due to damage to the machine! Since a check to ensure a de-energized state is mandatory after every intervention in the machine (Germany: check in accordance with DIN VDE 0701-1), only qualified electricians may open the machine!

Only BEGO replacement and wearing parts may be used.

Care and maintenance - Switch off the machine and pull out the mains plug before performing any care, cleaning or maintenance work.

Only use dry or slightly moist cloths for cleaning. Do not spray the machine with water or immerse it in water.

Maintenance of safety-relevant components

The unit has been designed for a service life of 10 years from the date of manufacture. No liability is accepted for damages arising from operation of the unit after this period.

Safety-relevant components must be checked regularly and replaced as required. This work must be carried out solely by BEGO customer service personnel or by repair centres authorised by the BEGO customer service department.

Special safety instructions regarding this device

⚠ DANGER

 **Danger due to electric shock**
Switch the device off and disconnect it from the power supply before carrying out any service or maintenance work!

⚠ WARNING

 **Risk of injury**
Cables and hoses must be laid in such a way that they do not pose a tripping hazard! Use cable ducts, bridges, etc.

⚠ WARNING

 **Risk of injury**
The resin is light sensitive and can cause allergic reactions.

- Observe the safety data sheet for the resin in use (→ <http://www.bego.com>).
- Observe the operating instructions.
- Wear protective gloves. Recommendation: Nitrile gloves.
- Use protective eyewear (safety glasses).
- Wear protective clothing.
- Protect from direct light / sun light.

⚠ WARNING

 **Risk of injury**
Any resin that has accidentally be spilled on the floor must be wiped and cleaned with ethanol and paper towels to prevent any slip hazard.

NOTE

Important! Never operate the device without supervision!

Carcinogenic agents

If resins originate from third-party sources then they must be free from carcinogenic agents.

We are not liable for any damage or personal injuries caused by the use of third-party resins.

Requirements for the production of medical devices

Under the Medical Devices Act (MPG) and other national regulations on the production of custom-made devices from medical products, laboratory operators are obliged to maintain a detailed and continuous documentation of the materials used. It must be possible to trace the manufacturer from the Batch Number.

Using the touchscreen

⚠ WARNING
 <p>Dangers from the touchscreen Any liquid that leaks as a result of damage is toxic and corrosive!</p> <p>Avoid contact with the skin, swallowing or breathing in!</p> <p>Only touch the touchscreen with the fingertips! Do not use sharp or pointed objects such as pens or your finger nail.</p>

The screen reacts to being touched and is used to enter commands. Using sharp or pointed objects such as pens or your finger nail can damage the screen.

Using resins

⚠ WARNING
 <p>Risk of injury</p> <ul style="list-style-type: none"> • The resin should not enter any bodily orifices such as the eyes and mouth, as this will cause a poisoning hazard. • Any resin spilt on the floor must be wiped up using ethanol and paper towels to avoid slip hazard. • Observe the safety data sheet for the resin in use (→ http://www.bego.com).

The VARSEO S cartridge should only be filled with resin or cleaned with ethanol under exhaust ventilation or in a well ventilated room to be protected against unpleasant odours and/or rising gases.

Broken glass pane

⚠ WARNING
 <p>Risk of injury Broken glass can lead to cutting injuries.</p> <p>Be careful with glass panes.</p>

Cleaning instructions → page 36 - 38.

⚠ WARNING
 <p>Risk of injury</p> <p>Any resin spilt on the floor must be wiped up using ethanol and paper towels to avoid slip hazard.</p>

Device description

VARSEO S - compact 3D printer with user-friendly operating and control concept

The device allows the printing of a number of dental 3-D objects using proven materials along with state-of-the-art Stereolithography Technology. This technology works with the principle of printing the object layer by layer using liquid resin and UV light. During the development of the device special dental technical requirements with regard to accuracy and practicality were paramount.

The unique container concept allows quick change of the printing material and makes pre-cleaning and removal of the object from the stamp for the resin receptor. Additionally the resin remains protected from damaging light due to the innovative container concept and therefore any artificial aging is reduced. The exposure unit is equipped with a powerful UV-LED. It ensures a rapid print and is maintenance-free and durable.

Data between the device and the PC is exchanged conveniently either via the network interface (LAN or WLAN) or the USB interface. The wide range of accessories facilitate immediate use. The technical design and the implementation of the most modern technology allows the 3-D printer to be used optimally in the laboratory as a piece of working equipment.

The BEGO VARSEO S has a user-friendly touch-screen, which is used to control all operations. However, the device can also be operated via a web browser from the workstation PC. If the print job (job file) is loaded from a USB flash-drive, then this can be done with the front USB socket. Alternatively, the job file may also be send to the machine via the local network. To that end, the device must be connected to the local network and the device software must be set up accordingly.

The Varseo S is available in two different editions (Partner edition / Basic edition); see details on page 13 "Varseo S Services". In order to activate the BEGO Varseo S 3D printer, the printer as well as the material to be used must first be registered under www.my.BEGO.com (see page 16). After the registration, you will be able to see and keep track of your system and your registered products, get access to software updates and be able to manage optional materials.

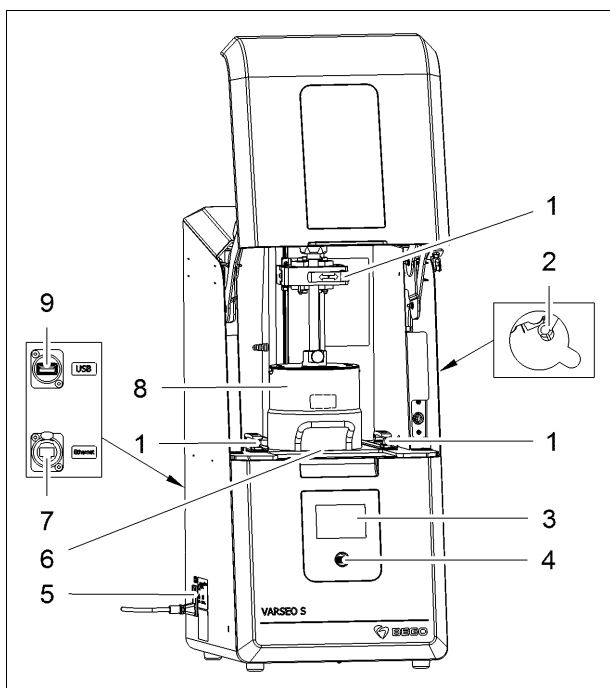

- 1 Lever
- 2 Emergency release of the cover using the lug
- 3 Touchscreen
- 4 Front USB socket
- 5 Main switch
- 6 Glass pane in the device
- 7 LAN socket (rear of device)
- 8 VARSEO S cartridge
- 9 USB socket (rear of device)

VARSEO S cartridge

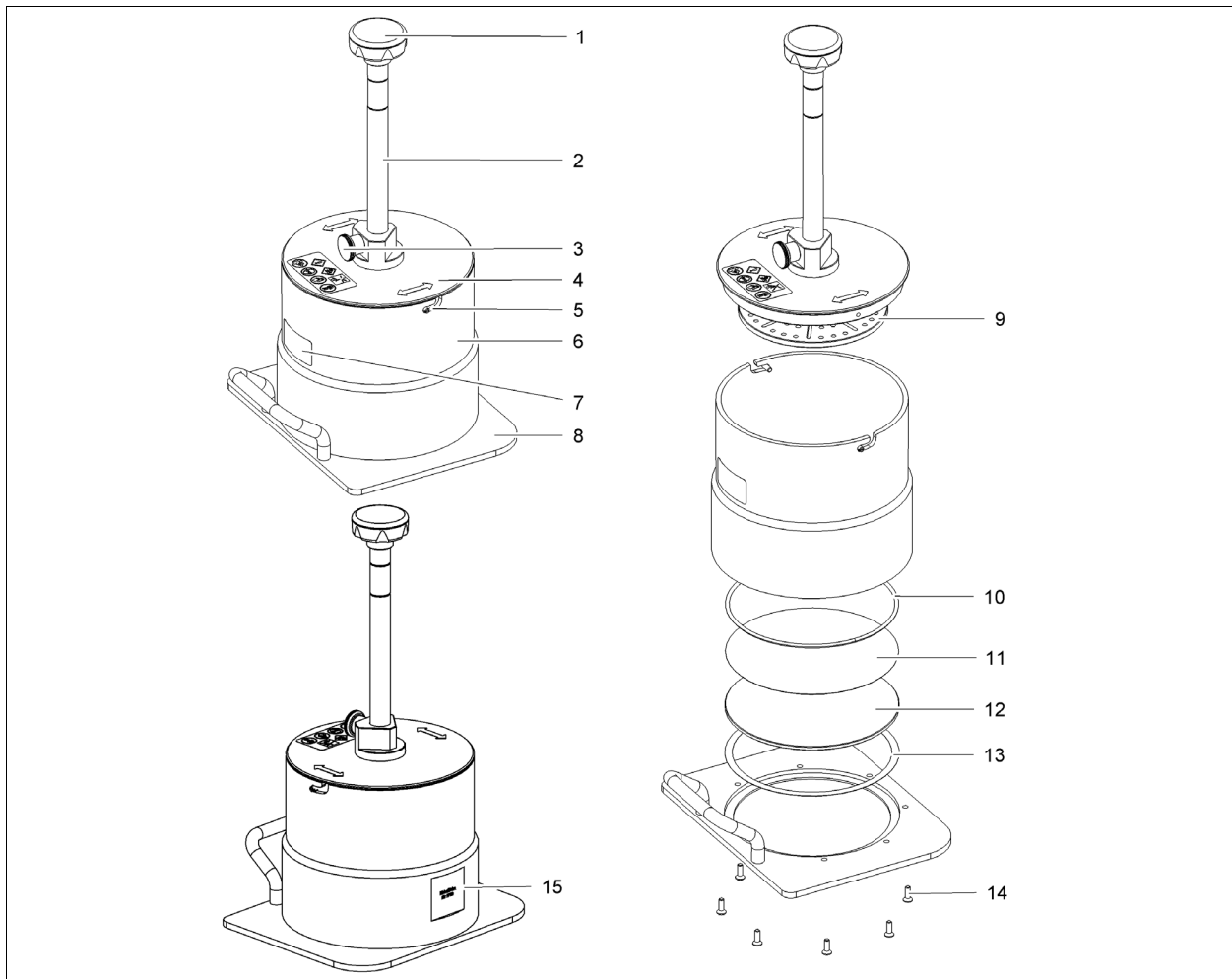

- 1 Star knob
- 2 Lift rod
- 3 Detent pin
- 4 Cover, VARSEO S cartridge
- 5 Bayonet coupling
- 6 VARSEO S cartridge
- 7 Cartridge label
- 8 Base plate with handle
- 9 Stamp with resin receptor
- 10 O-seal
- 11 Non-stick film
- 12 Borosilicate glass plate
- 13 Protective ring
- 14 Screws
- 15 Space for RFID chip

The resin mixture needed for a print job is filled into the VARSEO S cartridge.

An RFID chip (adhesive label) is affixed to the resin package; this label must be placed on the designated space on the VARSEO S cartridge. It serves to identify the resin; every time a new resin package is opened.

Pay attention to the proper allocation of the VARSEO S cartridge A/B: VARSEO S cartridge B for surgical guide clear, model, temp and VARSEO S cartridge A for CAD/CAST, tray, surgical guide, dent, splint.

A sealing ring, a non-stick film, a glass plate and a protective ring are located in the bottom area. These can be replaced whenever necessary (→ page 36 - 40).

Stamp with resin receptor - The finished object remains on the stamp after the print job has been completed. A spatula facilitates an easy and clean removal of the print job from the stamp.

Scope of delivery and accessories

Available forms	REF	Material packages	REF
VARSEO S Partner	26460	<ul style="list-style-type: none"> • Material package VarseoWax CAD/Cast (VarseoWax CAD/Cast 1 kg + cartridge incl. stamp + VarseoVest P 6 kg)..... • Material package VarseoWax Tray (VarseoWax Tray 1 kg + cartridge incl. stamp)..... • Material package VarseoWax Surgical Guide (VarseoWax Surgical Guide 1 kg + cartridge incl. stamp)..... • Material package VarseoWax Surgical Guide clear ¹⁾ (VarseoWax Surgical Guide clear 1 kg + cartridge incl. stamp)..... • Material package VarseoSmile Splint (VarseoSmile Splint 1 kg + cartridge incl. stamp)..... • Material package VarseoWax Model (VarseoWax Model 1 kg + cartridge incl. stamp)..... • Material package VarseoSmile Dent opaque pink²⁾ (VarseoSmile Dent opaque pink 1 kg + cartridge incl. stamp)..... • Material package VarseoSmile Dent pink ²⁾ (VarseoSmile Dent pink 1 kg + cartridge incl. stamp) • Material package VarseoSmile Dent dark pink²⁾ (VarseoSmile Dent dark pink 1 kg + cartridge incl. stamp) • Material package VarseoSmile Temp A3 (VarseoSmile Temp A3 0.5 kg + cartridge incl. stamp) • Material package VarseoSmile Temp A2¹⁾ (VarseoSmile Temp A2 0.5 kg + cartridge incl. stamp) • Material package VarseoSmile Temp C2¹⁾ (VarseoSmile Temp C2 0.5 kg + cartridge incl. stamp) 	41053
VARSEO S Basic	26455		41054
Scope of delivery		REF	
• Original operating instructions Varseo S.....	86087		
• Wooden spatula, non-sterile	19548		
• Bubble syringe, sterile.....	19549		
• Stainless steel spatula	19550		
• Card set, blank.....	19551		
• Torque screwdriver, 1.5 Nm.....	19556		
• Torque bit T20 x 25 mm.....	19557		
• O-ring	19524		
• Protective cap for VARSEO S cartridge..	19563		
• Power cable	12622		
• Power cord IEC connector USA.....	12554		
• Testing gauge, small.....	19409		
• Testing gauge, large	19410		
• WLAN-USB-Adapter-150Mbit/s	20119		
• VARSEO S cartridge, complete with stamp (Varseo S Basic)			
• Non-stick film			
• Special USB flash drive, calibration file			
• Touch pen			
Accessories		REF	
• CAMbridge licence dongle	20370		
• BEGO Otoflash light curing device	26465		
Cartridge types		REF	
• VARSEO S cartridge A (for CAD/Cast, Tray, Surgical Guide, Dent, Splint)	20008		
• VARSEO S cartridge B (for Surgical Guide clear, Model, Temp)	20360		

¹⁾ expected to be available in the third quarter of 2017

²⁾ expected to be available in the fourth quarter of 2017

Accessories

- Varseo accessories set.....41041
 - Varseo atomizer bottle (1x)
 - Varseo atomizer (1x)
 - Varseo measuring cup (1x)
 - Varseo plastic cup (2x)
 - Varseo acid forceps (3x)
 - Varseo funnel (1x)
 - Varseo PVC dental stone cup (1x)
 - Varseo brush (1x)
 - Hazardous substance label Ethanol de/en (1x)
 - Varseo screen holder (1x)
 - Filter for Varseo screen holder (125x)
- Varseo ejector device19056
- Varseo plastic cup41045
- Varseo acid forceps41046
- Set, Varseo screen holder with filter41047
- Filter for Varseo screen holder41048
- Varseo brush41049

REF

- Varseo atomizer bottle 41052

Wear parts

REF

- Filter mat 19442
- Slide plate 19961
- Borosilicate glass 19510
- Non-stick foils (set - 5 pieces)..... 19417
- O-Ring..... 19524
- Protection cap for Varseo cartridge..... 19563
- Foil replacement kit Varseo..... 19778
- Locking pin 19516
- Protective ring 20357

Additional material and accessories are available upon request.

NOTE

All **wear parts** listed here will *not* be replaced free of charge under the warranty or BEGO guarantee.

Varseo S Services

Varseo S services		
	Partner package	Basic package
Activation (inclusive)	Activation of a material key of your choice and making the corresponding material package available	Activation of all offered material keys
MDR ¹⁾ ready (inclusive)	Validated processes from scanning to finishing, including documentation and material-specific guidelines	Validated process from scanning to finishing, including documentation and material-specific guidelines (for materials approved by BEGO only)
Online access (inclusive)	To all areas of the BEGO 3D Academy	To selected areas of the BEGO 3D Academy
Support (inclusive)	<ul style="list-style-type: none"> • Device installation, commissioning and instruction in your laboratory • Professional hotline support • Loan unit in the event of damage/malfunction within the first 48 hours (as part of the 1 year guarantee) 	<ul style="list-style-type: none"> • Professional hotline support
Services (not included/subject to fees)	<ul style="list-style-type: none"> • Activation of additional material keys 	<ul style="list-style-type: none"> • Installation of the device, Commissioning and instruction in your laboratory

¹⁾Medical Device Regulation

Technical data

Height max.	748 mm	Ambient temperature	20 - 30 °C (57 - 86 F)
Width	362 mm	Max. allowed humidity	80%
Length	461 mm	Elevation.....	up to 2000 m
Weight	47 kg	Print volume	110 x 64.8 x 85
Nominal output.....	100 VA	Resolution	±30 µm
Nominal voltage	100-240 V AC, 50/60 Hz	Layer	50 to 100 µm
Noise emission.....	< 70 dB(A)	Print rate.....	20 to 40 mm/h

Installation

NOTE

Ensure ample space to the wall so that the lid can be opened without being obstructed and that there is sufficient space for ventilation.

Electricity

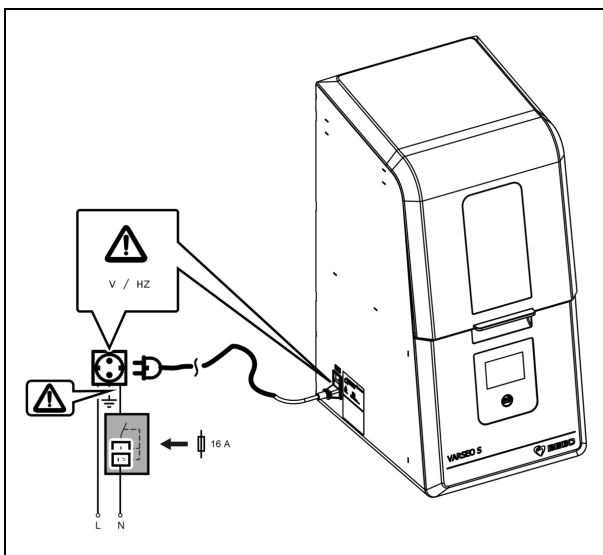

⚠ DANGER



Danger due to electric shock

Check if the specifications on the type plate correspond to the power supply network before connecting the device. Consult an electrician in case of uncertainty.

The device is subject to protection class I and must only be connected to properly grounded power sources.

Basic principles

VARSEO S uses a powerful LED light source to create plastic objects from a liquid resin mixture. To prevent premature solidifying of the resin mixture it should only be used in a light protected and darkened environment. There will still be some non-solidified resin on the object after the print job has been completed. Any further solidifying of the resin reduces the accuracy of the manufactured object.

NOTE

Important! Protect any non-solidified (liquid) resin mixture from direct or strong light in the area!

The construction of the object takes place with individual layers which bond to each other. Every new layer solidifies on the non-stick film, which is located on the bottom of the cartridge. Any damage to the non-stick film can lead to flaws in the solidified layer and therefore cause flaws in the object.

NOTE

Important! Check the non-stick film for signs of damage prior to starting the print job and replace it, if necessary (→ page 40).

When the VARSEO S is delivered, it is set-up so that the stamp dispensing the resin is parallel to the non-stick film. Should they not be parallel, the print job may become detached from the stamp, the layers may only bond poorly and the lift rod may twist inside the cap.

NOTE

Important! Please contact the BEGO customer service department for proper realignment.

Initial commissioning

Activating the VARSEO S at myBEGO

The activation of your BEGO Varseo S 3D printer requires prior registration.

Using your chosen access data, you can login to www.my.BEGO.com at any time and profit from many advantages:

- You will be the first to receive news and information. We will inform you about new products, tips and tricks for your BEGO Varseo 3D print system, scheduled webinars and much more.
- Support section: profit from the FAQ, guidelines and video tutorials to make optimum use of your BEGO Varseo 3D print system.
- After registration, we will send you an e-mail to the specified e-mail address, which will contain the user information that you have chosen. Please note that the VARSEO S printer must be online and registered on www.my.BEGO.com in order to execute print jobs!

1. Open the "BEGO Varseo Activation.exe" file in the "Profile" folder on the supplied USB flash drive.
2. Enter all required data and confirm the entries to activate your printer with myBEGO.
3. The activation will take place automatically.

NOTE

Please install the CAMbridge software, which is contained on the supplied USB flash drive, on your computer to use the printer. The licence dongle of the software is not included in the scope of delivery.

Setting up a network connection via LAN cable

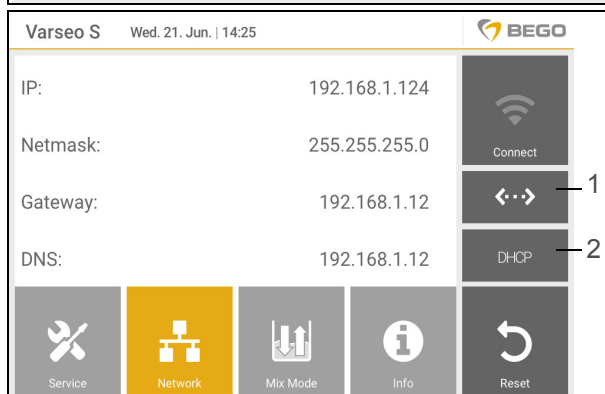
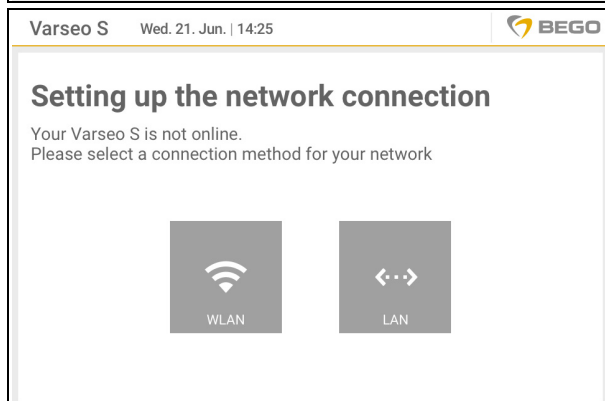
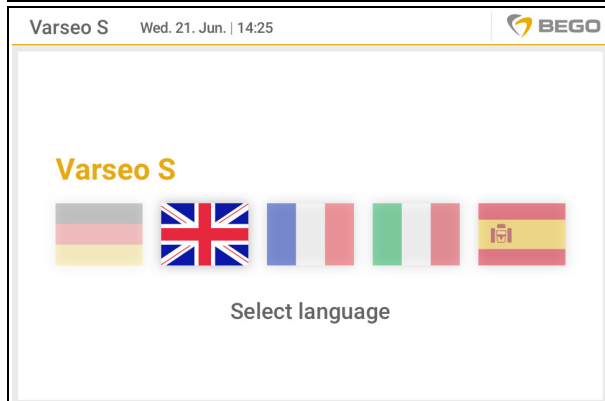
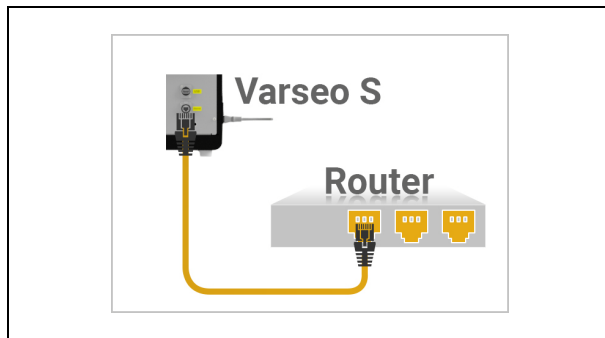

Your device requires a network connection with myBEGO in order to acquire the desired indications.

NOTE

The VARSEO S device must be switched off.

NOTE

Only connect the VARSEO S via LAN or WLAN; otherwise, the host name cannot be clearly allocated! Contact an IT expert, if needed.

1. Plug the LAN cable into the Ethernet socket on the back of the VARSEO S.
2. Connect the other end of the LAN cable with the "LAN" socket of your router / network connector.
3. Switch the VARSEO S on with the power switch located on the right side of the device. The BEGO software will be loaded.
4. Select the language.
5. Press the LAN button.

NOTE

If your network supports DHCP, the VARSEO S will automatically connect with your network.

The device will display an error message if no connection could be established between the network and the device.

6. Check under "Settings" > "User Menu" > "Network" if the entries are correct. LAN and DHCP must be activated!
 Button 1: Selection "LAN" or "WLAN"
 Button 2: Selection "DHCP" or "Static"
7. If DHCP is not supported by your network, use the expert mode "Static". Please consult an IT expert to that end.

Setting up a network connection via WLAN

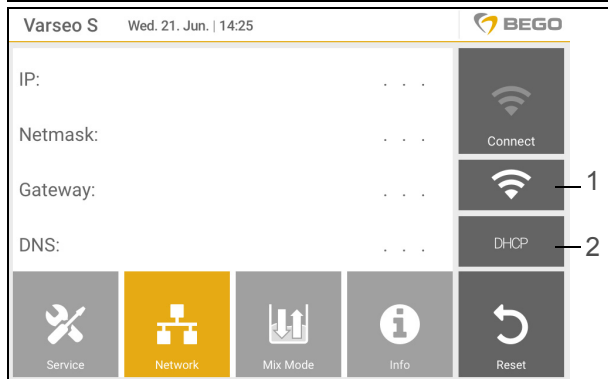
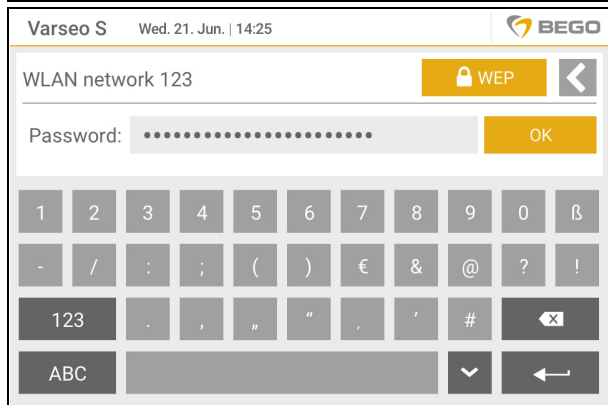
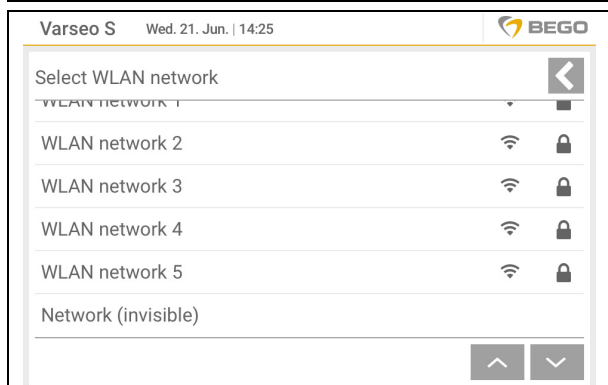
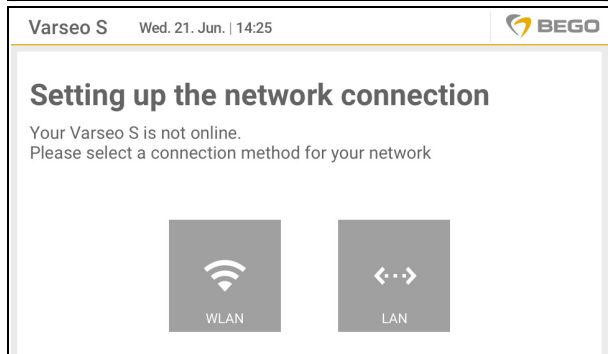
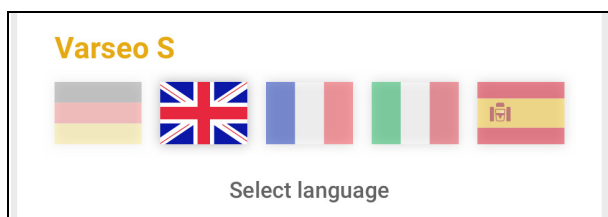

1. Insert the WLAN USB adapter on the back of the device.
2. Switch the VARSEO S on with the power switch located on the right side of the device. The BEGO software will be loaded.
3. Select the language.
4. Press the WLAN button.

NOTE

Only connect the VARSEO S via LAN or WLAN; otherwise, the host name cannot be clearly allocated! Contact an IT expert, if needed.

5. Select the WLAN network.
If the WLAN network is invisible, select SSID and the encryption type (WEP, WPA2, etc.).
6. Enter the password.
7. Press the OK button.
Wait until the connection process is completed.
8. If it was not possible to establish a connection, check the entries under "Settings" > "User Menu" > "Network".
9. Select "WLAN" under button 1 and "DHCP" under button 2. Press the "Connect" button.
10. If DHCP is not supported by your network, use the expert mode "Static". Please consult an IT expert to that end.

Checking the network connection with the "Varseo S - Service Board"

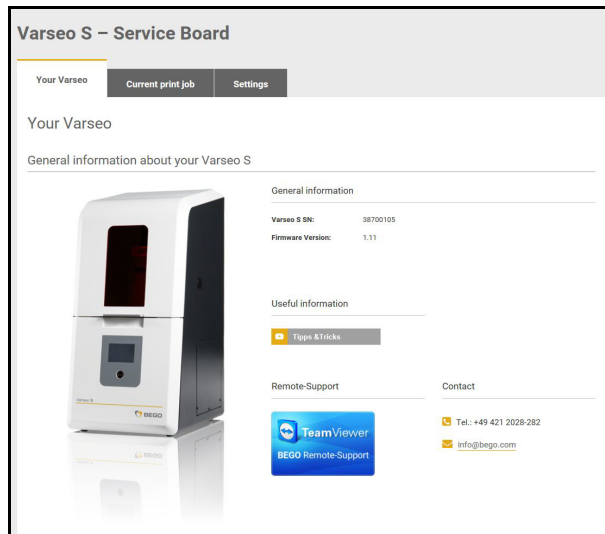

1. Call up the internet browser on the workstation PC.
2. Enter the web-address of VARSEO-S (varseo+serial-no., e.g. "varseo38200101"). The serial number can be found on the device's type plate. Alternatively, enter the IP-address of the printer into the browser (will be displayed in the "Settings" menu). The web interface VARSEO S-Service Board will appear! Here, you can call up information about the printer, the print job and the printer settings, see page 33.

Automatic firmware update

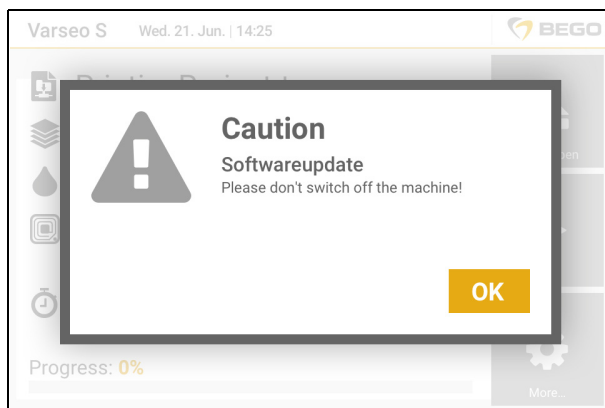

NOTE

The VARSEO S will automatically update the device software to the latest firmware version via my.BEGO. The Varseo S checks for new versions to be installed every time it is restarted and after every print job.

Do not switch the device off during an update. The printer will restart after an update.

Filling the VARSEO S cartridge

⚠ WARNING



Risk of injury

The resin is light sensitive and can cause allergic reactions.

- Observe the safety data sheet for the resin in use (→ <http://www.bego.com>).
- Observe the operating instructions.
- Wear protective gloves. Recommendation: Nitrile gloves.
- Use protective eyewear (safety glasses).
- Wear protective clothing.
- Protect from direct light / sun light.

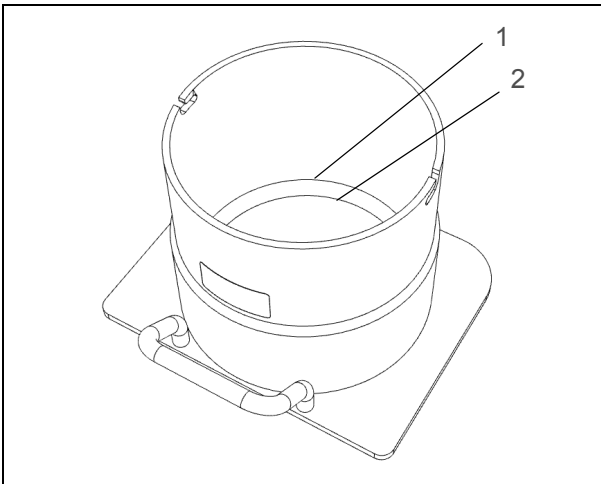

- 1 Max. fill level (approx. 500 ml)
- 2 Min. fill level (approx. 100 ml)

⚠ WARNING



Risk of injury

Any resin that has accidentally be spilled on the floor must be wiped and cleaned with ethanol and paper towels to prevent any slip hazard.

Removing the VARSEO S cartridge from the device

1. Press the "Cover open" button, the cover will open.
2. Open the levers marked with yellow arrows and use the handle to pull the cartridge out of the holding fixture.
3. Pull the plunger out of the cartridge until the stop bolt latches,
4. Unscrew the cap of the cartridge counterclockwise and remove it.
5. Clean the cartridge, → Cleaning the VARSEO S cartridge, see page 36.

NOTE

Remove the RFID chip and any resin residue from the cartridge before filling it with a new bottle; affix the new RFID chip.

Pay attention to the correct cartridge type A/B before filling, see page 12.

The fill level must be between the max. and min. level marks.

When refilling make sure that there is no solid residue in the resin. Otherwise the resin must be filtered so that it can be used.

The cartridge of the VARSEO S cartridge must be filled **outside of the device**.

The VARSEO S cartridge will be filled with the corresponding resin up to the fill level after it has been assembled and cleaned. If there is any residue outside the cartridge inner part this should be carefully removed.

1. Place the cap on the filled VARSEO S cartridge and lock the two components by turning the bayonet coupling.
2. Release the plunger from the stop bolt and carefully lower the stamp into the resin; apply slight pressure, if necessary.
3. Remove the RFID chip (adhesive label) of the new resin package and affix it to the blank space on the cartridge that it intended for that purpose; see page 11 (remove old RFID chip beforehand).

Interface to the CAMbridge software

The CAMbridge software allows you to create and process different dental objects for the VARSEO S.

NOTE

If you do not have admin rights then have the installation and the update carried out using admin rights or contact an administrator to have this done.

Item	Minimum	Recommendation
OS	Windows 7 32-bit Professional	Windows 8.1 64-bit Professional
RAM	4 GB	8 GB
Video Card	DirectX 10	1 GB DirectX 11 NVIDIA GeForce
Available HDD Space	250 GB	500 GB
CPU	Intel Core i3 or equivalent	Intel Core i7 or equivalent
Monitor	1366 x 768	1920x1200
3D mouse	-	3D Connexion Space Explorer
Network	Internet connection	
Mouse	With mouse wheel support	

Licenses and site usage

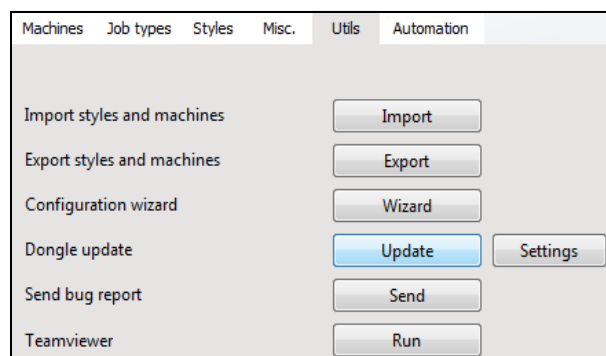

If the dongle does not have the correct period of validity the dongle must be updated. This is done via the menu item Option > Utils > Dongle > Update (→ Figure)

Machine data export

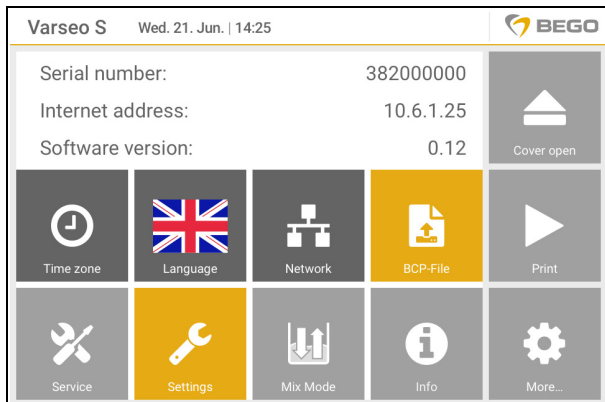

Be aware that there are individual machine parameters for every device. These machine parameters can be found on the supplied flash drive as well as in the "Settings" menu on the device. In case data is lost, the machine parameters can be exported from the VARSEO S to a USB flash drive as follows:

1. Insert an empty USB flash drive into the VAR-SEO S
2. Call up "Settings" > "User Menu".
3. Select "BCP File" when the button is highlighted in orange and the arrow points up. The button will start to flash.
4. The data will be exported. Wait until the button stops flashing.
5. Remove the flash drive.
6. Save the exported BCP file, accessible for everybody, on the computer so that parameters can be accessed easily afterwards.

Alternatively, the "Varseo S - Service Board" may be used for the BCP export, which can be accessed via the network in the browser.

The initial print job with a test file

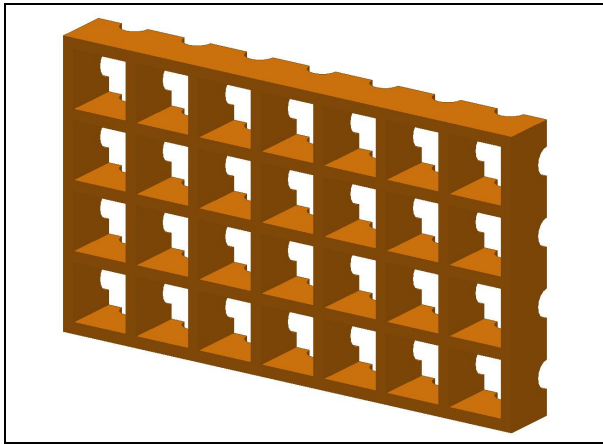

Fig. 1 Test specimen

The first print job is done with a test file and carried out by the installation personnel and just demonstrates that the device is in perfect working order. The test object can be printed with all resins. After cleaning and post-hardening of the test object this can be inspected using the test gauge from the accessories.

After the first successful print, the attached "instruction protocol" must be signed by authorized lab staff and the installation personnel.

Keep the original of the certificate in a safe place, as this may be required for any possible warranty claim!

- *Visually*, unevenness, fringes, dents and a lack of sharpness, which are indicated by rounded edges, may be observed on the object.
- *Geometrically* the fit is measured in positive and negative direction. The testing gauge for the fit in the x and y directions is laid over the test specimen.

The following applies when assessing the test object:

Testing gauge (+)	Testing gauge (-)
<p>Must fit over the grid</p>	<p>May not fit over the grid</p>

The z direction is examined by means of the test mandrels located on the testing gauge.

Place the corresponding mandrel between the two walls of the test specimen and check to which extent (-) or (+) fit or not; try to tilt the test gauge back and forth during that process.

With the test specimen (-), the tip of the test mandrel must not reach the bottom; therefore, the test gauge must not tilt when applied.

With the test specimen (+), the tip of the mandrel reaches the bottom; however, it should not reach the sides of the grid and must allow tilting.

If the mandrel of test specimen (-) reaches the bottom or if the mandrel of test specimen (+) does not reach the bottom, please contact the service department.

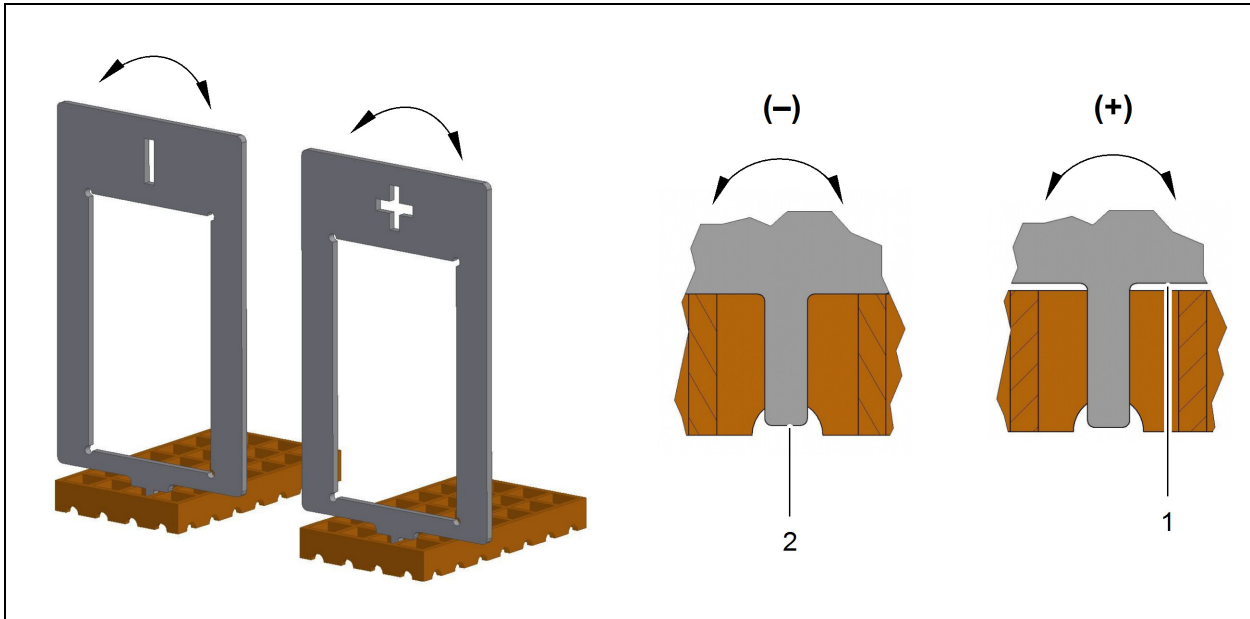

- 1 (+) is too large
- 2 (-) is too small

Operation – Device hardware

⚠ WARNING



Risk of injury

The resin is light sensitive and can cause allergic reactions.

- Observe the safety data sheet for the resin in use (→ <http://www.bego.com>).
- Observe the operating instructions.
- Wear protective gloves. Recommendation: Nitrile gloves.
- Use protective eyewear (safety glasses).
- Wear protective clothing.
- Protect from direct light / sun light.

Preparing the VARSEO S cartridge

NOTE

- The glass plate of the VARSEO S cartridge must be free of any solidified resin residues (it is best to clean the surface of the cartridge before filling in the resin). Clear the stamp picking up the resin from any solidified residues.

The VARSEO S cartridge must be checked for resin residue and thoroughly mixed before a job is started.

1. Place the cap on the filled VARSEO S cartridge and lock the two components by turning the bayonet coupling.
2. Release the lift rod from the locking pin and carefully lower the stamp into the resin; apply slight pressure, if necessary.

Right:

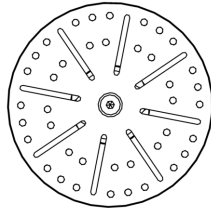

Wrong:

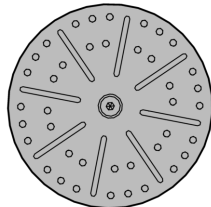

NOTE

- In order to check if the stamp collecting the resin is resting flush with the bottom of the VARSEO S cartridge, you should lift the VARSEO S cartridge and look at the bottom of it. There must only be a thin gap between the non-stick film and the stamp (illustration on the left)
- The lift rod must be free of resin residue. Otherwise they cannot move freely, and could cause incorrect printing.

Switch-on and loading print objects

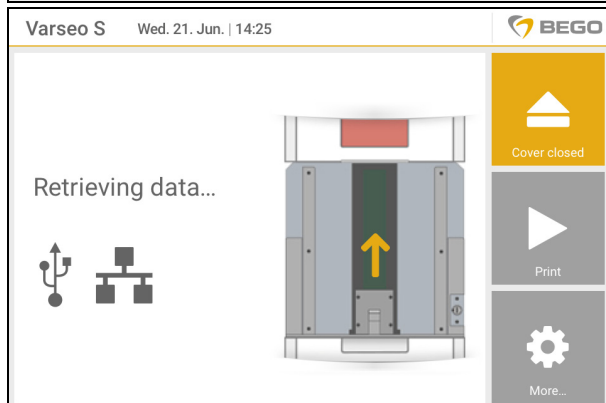
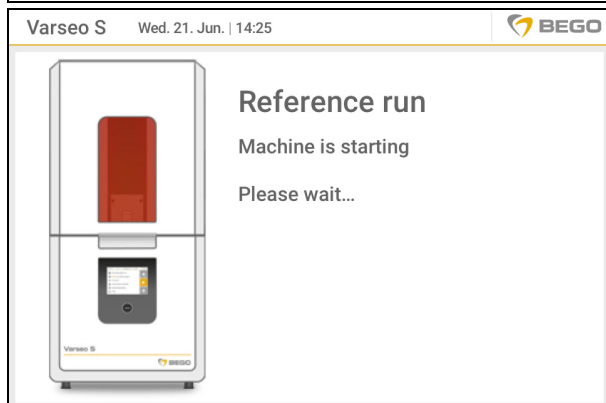

1. Switch on the device.
The device performs a reference run.
After 2-3 minutes the unit is ready for operation.
The menu box opens (→ illustrations).

NOTE

The VARSEO S cartridge must not be inside of the device during a reference run. The cover must be closed and all the levers open.

2. Send the print job to the printer, either via the supplies USB flash drive, with CAMbridge via the network or via the VARSEO S Service Board (for further information, please refer to chapter "Operation via Web Interface", page 33).
As long as no USB flash drive is plugged into the port or if the file cannot be found via the network, the menu box will be indicating that the system is searching for a file .
3. Press the "Print" button and select a job file.

NOTE

Please note, that the VARSEO S printer must be online and registered on www.my.BEGO.com to execute print jobs!
Setup see page 16 ff.

Selecting a print job

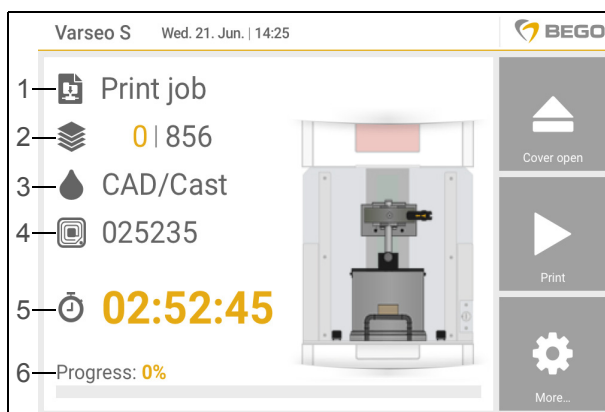
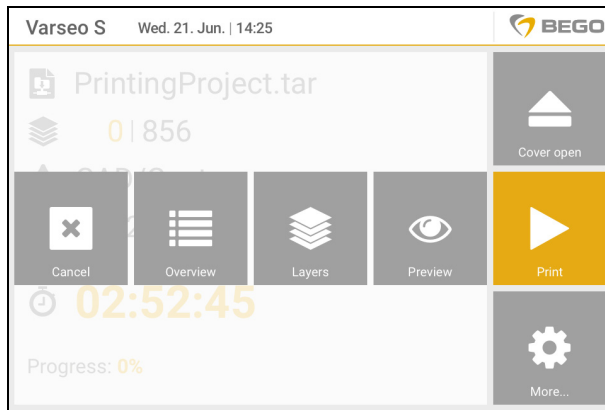

1. Job name
2. Number of layers with currently printed layer
3. Resin used
4. RFID chip number
5. Remaining time in bego-yellow or expected total print time in bego-gray

6. Progress bar

Files can be send to the printer via the supplied USB flash drive, with CAMbridge via the network or via the "Varseo S Service Board".

NOTE

Please note that the VARSEO S printer must be online and registered on www.my.BEGO.com in order to execute print jobs!

Setup see page 16 ff.

1. In the print menu, all print jobs available on the USB flash drive and on the network are listed and can be chosen. Select the correct print job (illustration see page 26)!
It is also possible to preview the selected print job or to display a detailed "layer view" (illustration on the left)
2. A print job can be aborted by pressing the "abort print" button and confirming the subsequent prompt in the print menu.
3. If a print job is loaded and the corresponding resin bottle is inserted, the device will display the following information (illustration on the left)
4. Pressing the "Print" button will start the print.

Automatic firmware update

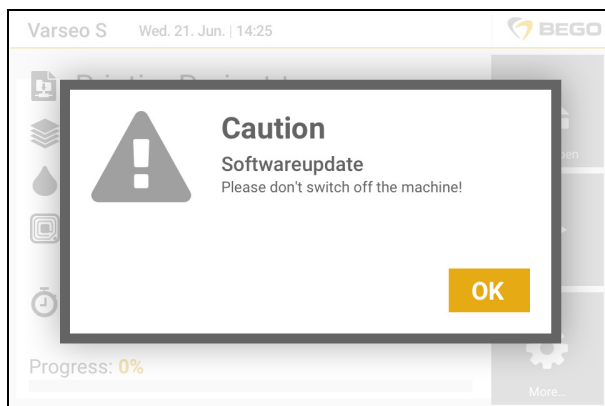

NOTE

The VARSEO S will automatically update the device software to the latest firmware version via my.BEGO. The Varseo S checks for new versions to be installed every time it is restarted and after every print job.

Do not switch the device off during an update.
The printer will restart after an update.

Settings



The following sub-menus can be called up from the "SETTINGS" menu:

Mix Mode - Mix mode will only be executed when it is activated. The job is then started by pressing the start button and the stamp moves up and down to mix the resin prior to printing.

The number and the speed of the mixing movements can be set/adjusted.

Our recommendation default settings are: normal and 10 repetitions

NOTE

The symbol for the Mix Mode is displayed on the start screen when activated.

Info - This button provides the user with assistance for working with the VARSEO S cartridge and the device.

User Menu: Language - The available languages include German and four other languages.

User Menu: Time - The current time is taken from the network. The correct time zone can be selected with the "+" and "-" button.

User Menu: Network - The setup of the network connection can be changed (→ page 16).

User Menu: BCP-File - This button is used to export the machine data to a flash drive and subsequently imported into CAMbridge (→ page 22).

Service - The service menu is reserved for the service personnel.

Print

⚠ WARNING**Crushing hazard**

There is a risk of crushing when installing the VARSEO S cartridge and closing the cover.

Be careful with your fingers.

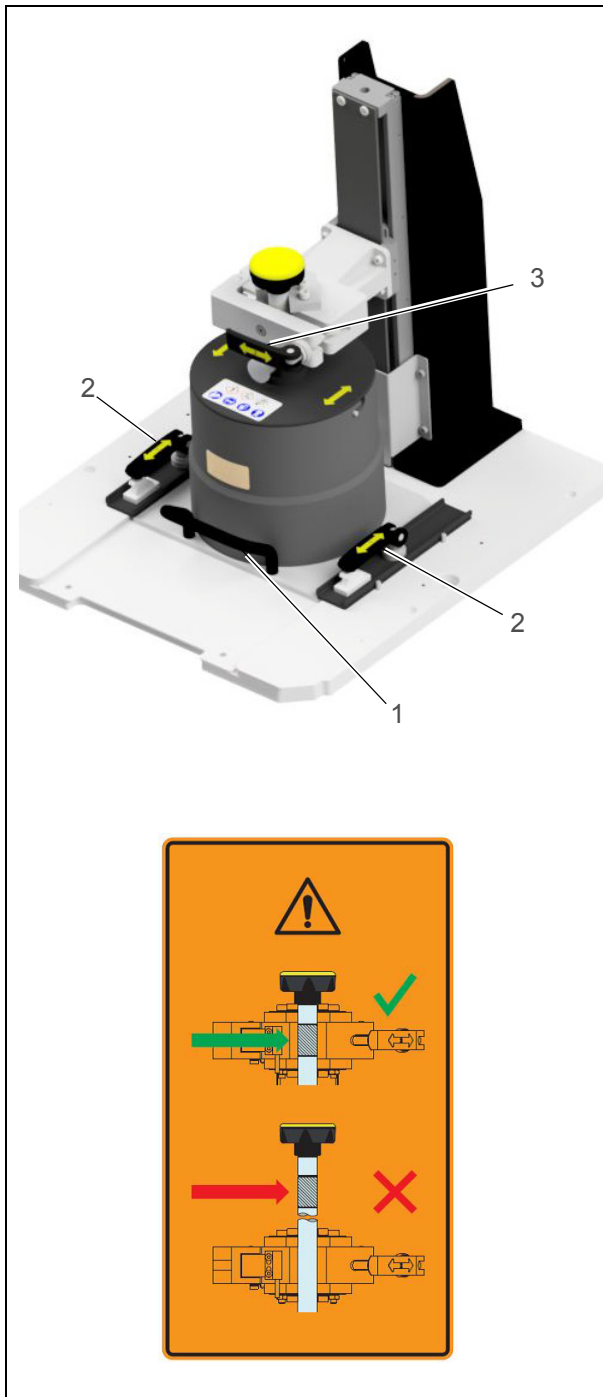
**⚠ CAUTION****Property damage**

- The lift rod must be clamped near the milled recess (→ Illustration below). Otherwise, an error message is issued.
- All screws of the lower lever (2) and the upper lever (3) must facilitate that the cartridge is firmly fastened. Otherwise, retighten them or contact the service department.

1. Open the cover after the reference run.
2. Push the VARSEO S cartridge against the fasteners using the front handle (1), then push down both of the bottom levers (2) and finally secure the upper lever (3).
3. Close the cover, select the print job and press the "Print" button. The job is executed.

Display screen → page 27

At any point in time the display shows the current layer being printed.

NOTE**Abort Job**

Press "Print" > "Abort print" and confirm the prompt if you need to abort a job while it is being printed,

The display indicates, which steps need to be executed.

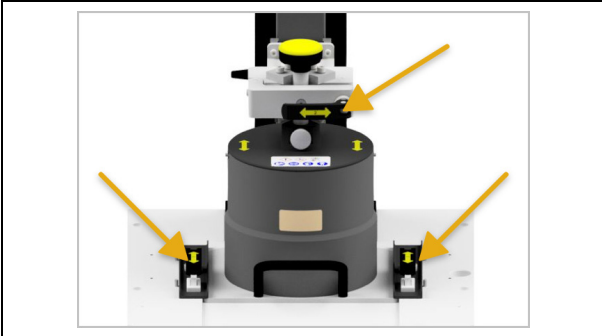

- Insert the VARSEO S cartridge and close all levers.

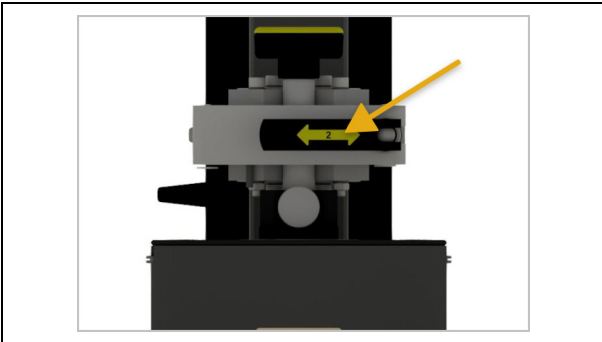

- Closing the upper lever (lever no. 2)

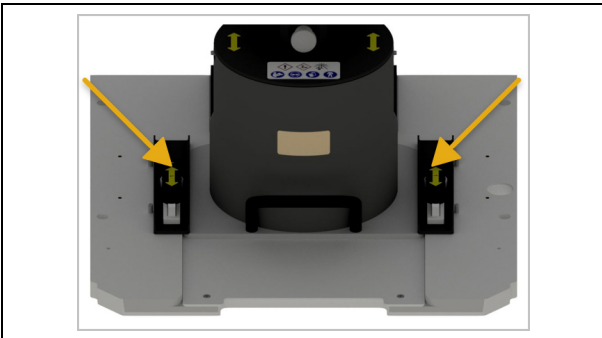

- Closing the bottom levers no. 1 (VARSEO S cartridge)

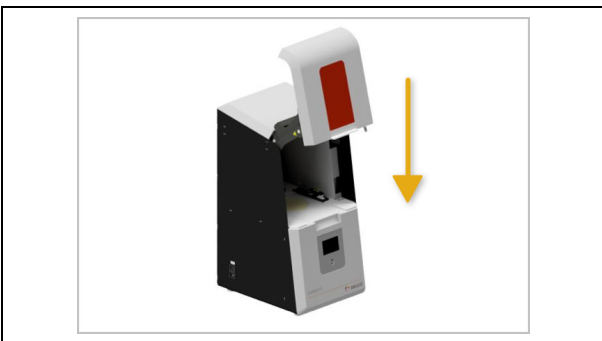

- Close the cover

End of print

Once all layers are illuminated, the display will indicate that the print is finished.

From this point on, the cover can be opened by clicking the button "Open cover", the lever can be released and the VARSEO S cartridge can be removed.

NOTE

It is possible that the lift rod is not latched on the stop bolt. In this case, this must be done manually.

After the print

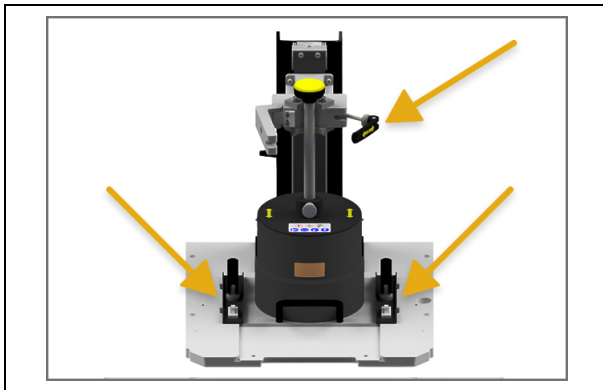

- Release all levers and remove the cartridge

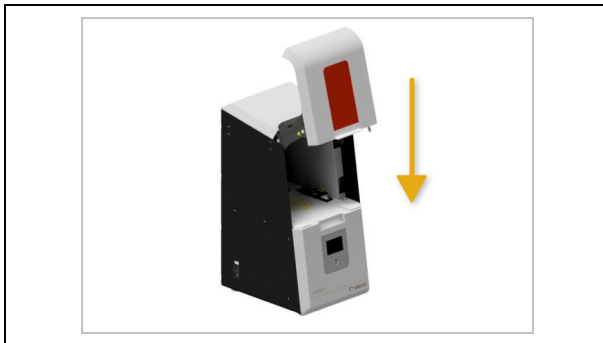

- Close the cover

Removing the print job from the bottom platform

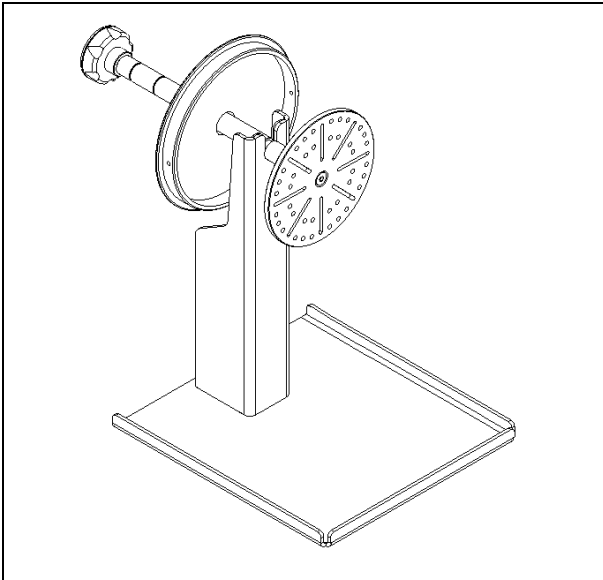
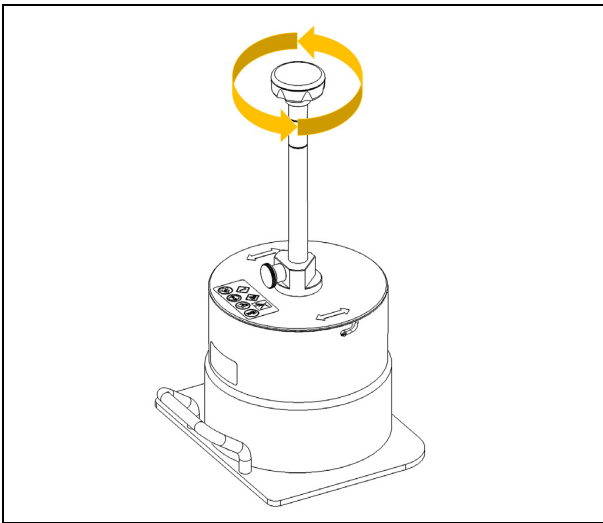

⚠ WARNING



Risk of injury

- Any resin that has accidentally be spilled on the floor must be wiped and cleaned with ethanol and paper towels to prevent any slip hazard.

1. Place the VARSEO S cartridge on free area. Make sure that the lift rod of the stamp is properly latched on the cover. Rotate the lift rod to remove any remaining resin from the object.
2. Release the bayonet coupling and remove the cover of the VARSEO S cartridge.
The ejection device into which the stamp is clamped horizontally (→ Accessories).
3. Carefully remove the object from the stamp using the spatula (→ Scope of delivery). Place the spatula on the grooves and holes of the stamp plate first.

Operation via Web Interface

The Varseo S Service Board allows you to view the printer and job information as well as setting up/adjusting the Varseo S via a network interface.

1. Ensure that a network connection has been established.
2. Start the workstation PC and call up the internet browser.
3. Enter the device-specific web address of the Varseo S in the address line (Varseo plus serial number, e.g. "http://varseo38200101"). The serial number can be found on the type plate

located next to the device's network connector. Alternatively, enter the IP-address of the printer into the browser (will be displayed in the "Settings" menu).

4. The device-specific service board will be called up.

NOTE

The web interface is continuously improved by means of updates and will have additional functions!

Printer information

Next to specific device information, you will receive tips and tricks regarding the use of the Varseo S as well as support information.

Varseo S – Service Board

Your Varseo
Current print job
Settings

Your Varseo

General information about your Varseo S



General information

Varseo S SN: 38700105

Firmware Version: 1.11

Useful information

▶ Tips & Tricks

Remote-Support

TeamViewer
 BEGO Remote-Support

Contact

 Tel.: +49 421 2028-282

 info@bego.com

Job information

The current print status and a preview of the selected job can be viewed. Print jobs can be sent to the printer by pressing the "Load project" button.

The screenshot displays the 'Varseo S – Service Board' interface. At the top, there are three tabs: 'Your Varseo', 'Current print job' (which is active), and 'Settings'. Below the tabs, the 'Job status' section shows 'Current job: ---'. A 'Load project' button is visible. The 'Progress' section features a large circular gauge showing '0%' and a 'Preview' area with a magnifying glass icon. To the right of the gauge, the following information is displayed: 'Remaining time:', 'Progress: 0/0', and 'Preview:'.

Settings

The Varseo S interface language and mix mode can be selected in the "Settings" menu.

NOTE

The web interface is continuously improved by means of updates and will have additional functions!

It is possible to set up the network connection:

1. Choose between Wifi and LAN.
2. LAN: Select "DCHP" under the LAN settings.
Wifi: Select the desired WLAN-network and enter the network key.

(Please consult an IT expert when using the expert mode).

3. Press the "Save" button.

NOTE

Only connect the VARSEO S via LAN or WLAN; otherwise, the host name cannot be clearly allocated! Contact an IT expert, if needed.

Varseo S – Service Board

Your Varseo
Current print job
Settings

Varseo S - Settings

Service-Login

General settings

Language

English (en)
▼

Save

Other

Mix Mode:

10

Network settings

Wifi
LAN

DHCP
Static settings

IPv4-Address: 10 . 3 . 0 . 12

Netmask: 255 . 255 . 0 . 0

Gateway/Router: 10 . 3 . 0 . 1

DNS-Server:

-
10 . 1 . 0 . 4

-
10 . 1 . 0 . 101

Save

Service and Maintenance

⚠ DANGER

 **Danger due to electric shock**
Switch the device off and disconnect it from the power supply before carrying out any service or maintenance work!

⚠ WARNING

 **Risk of injury**
The resin is light sensitive and can cause allergic reactions.

- Observe the safety data sheet for the resin in use (→ <http://www.bego.com>).
- Observe the operating instructions.
- Wear protective gloves. Recommendation: Nitrile gloves.
- Use protective eyewear (safety glasses).
- Wear protective clothing.
- Protect from direct light / sun light.

Cleaning

⚠ WARNING

 **Risk of injury**
Ethanol is highly flammable.

- Keep the container closed tightly.
- Keep away from sources of ignition – No smoking.
- Observe the safety instructions on the packaging.

⚠ CAUTION

 **Property damage**
Do not use any chemical and aggressive cleaning agents, as they may damage the finish of the unit.

If necessary, clean the machine on the outside with a dry or slightly moist cloth and non-aggressive detergent.

Cleaning the VARSEO S cartridge

NOTE

It is recommended to use a separate VARSEO S cartridge for every resin.

1. First sieve the resin contained in the cartridge and fill it into the corresponding resin bottle. Do this by using a suitable funnel and place the recommended screen on to it.
2. Clean the cartridge from any residual resin using ethanol and towels.
3. Check the non-stick film and the glass plate for any contamination and signs of damage (→ page 40).

4. As soon as VARSEO S cartridge is free from any resin residue, clean it again with paper towels and ethanol and allow it to dry.

Cleaning the plunger for resin reception

1. Since solidified resin residue can stick to the holes after printing, it is recommended to clean the clogged holes with cotton buds, wooden sticks or a right angled hexagon socket wrench from any residues.
2. Then rinse with ethanol in order to remove any liquid resin residues, cotton wool or similar.
3. Finally, clean the stamp with cloths.

Cleaning the glass pane

⚠ WARNING	
	Risk of injury Broken glass can lead to cutting injuries. Be careful with glass panes.

⚠ CAUTION	
	Property damage Do not use any glass cleaner in the device! Glass panes may be used in the device only when dry!

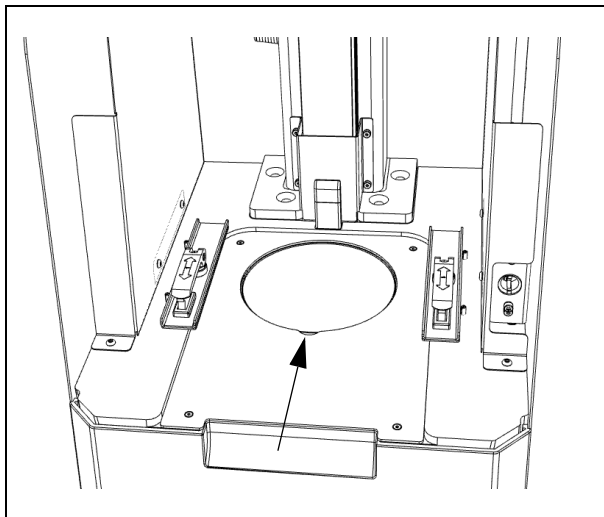

Check the glass plate in the device and in the bottom of the VARSEO S cartridge for any contamination prior to every print job (e.g. resin residue, fingerprints). Replace or clean the glass pane with a cloth and glass cleaner if necessary. To do this the pane should be removed before cleaning as follows: Grip with a spatula or finger nail into the notch, pull out the pane and clean away from the device. The arrow in the adjacent illustration shows the position of the notch in the device.

Removal of spilled resin

WARNING



Risk of injury
Broken glass can lead to cutting injuries.

Be careful with glass panes.

WARNING



Risk of injury
Risk of slipping

Any resin spilt on the floor must be wiped up using ethanol and paper towels to avoid slip hazard.

If the glass pane should break **outside** the device, causing resin to escape, proceed as follows:

1. Avoid light sources,
2. Wear protective clothing (safety goggles, protective gloves and lab coat).
3. Wipe-up the resin using paper towels and
4. clean the soiled areas with the help of ethanol and towels. The cloths that have taken up the liquid resin should be disposed of according to the rules for hazardous waste.

Should the VARSEO S cartridge leak and resin spills into the device, proceed as follows:

1. Unplug the power cord,
2. do not operate the equipment and
3. inform the service.

Service Messages

VARSEO S has incorporated several maintenance instructions to ensure a long service life of the VARSEO S cartridge.

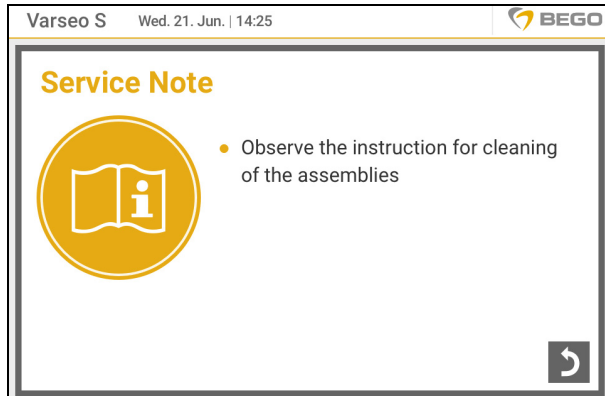

Maintenance instructions for the operator -

The first service note will be displayed on the VARSEO S screen after every fiftieth print job.

1. Clean the VARSEO S cartridge and both glass plates.
2. Check the non-stick film for signs of damage and replace it, if needed (→ page 40).

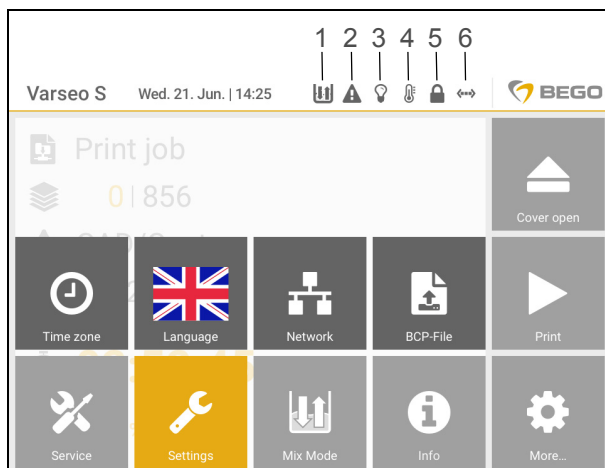

Maintenance instructions for the service -

Light bulb: Lights up when the light intensity of the UV light source is too low.

1. Inform the service department.

Maintenance note ambient temperature -

Thermometer: Lights up when the device senses a temperature above 35 °C or below 15 °C.

1. Make sure that the device is not exposed to temperatures outside the specified temperature range.

- 1 Mix Mode (→ page 28)
- 2 Warning message
- 3 Light bulb
- 4 Thermometer
- 5 Packages/editions (Basic or Partner)
- 6 Network

Applying the non-stick film

⚠ WARNING



Risk of injury

Broken glass can lead to cutting injuries.

- Be careful with glass panes.
- Wear protective gloves. Recommendation: Nitrile gloves.
- Use protective eyewear (safety glasses).
- Wear protective clothing.

Auxiliary equipment:

- Torque wrench (1.5 Nm)
- Torque bit T20 x 25 mm
- Protective gloves, facial tissues, ethanol
- Removal aid (e.g. a wooden spatula wrapped in a soft cloth, squeegee)

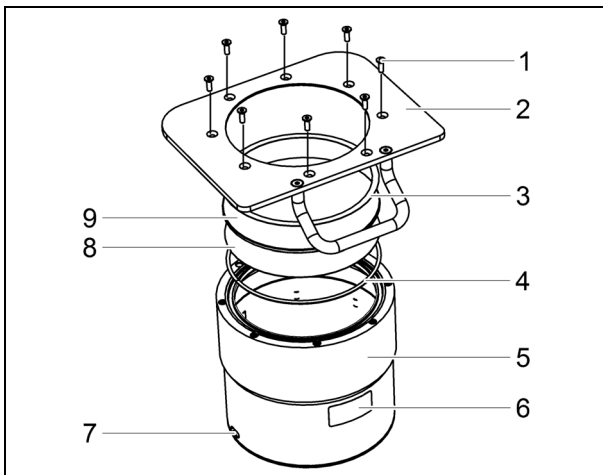

- | | | | |
|---|------------------|---|----------------|
| 1 | Screws | 2 | Base plate |
| 3 | Protective ring | 4 | Seal |
| 5 | Cartridge | 6 | Type plate |
| 7 | Bayonet coupling | 8 | Non-stick film |
| 9 | Glass plate | | |

NOTE

The non-stick film should be replaced at regular intervals so that scratches or the like on the used non-stick film do not negatively affect the results. When properly used, the non-stick film will last for up to 50 print processes. When printing complete models, the non-stick film will last for 10 ±5 print jobs.

Do not scratch or damage the non-stick film and the glass plate when replacing them.

1. Turn the VARSEO cartridge upside down and remove the eight smaller screws using the torque wrench. Subsequently remove the bottom plate with the protective ring from the cartridge and place the glass plate with the non-stick film, which is located between the glass plate and the cartridge, onto a flat surface that is covered with tissue. Pull the old non-stick film off the glass plate.
2. Clean the glass plate and the new non-stick film with soap. Wear gloves to avoid any smudging. Clean both components dry lint-free cloth.
3. Place the dry non-stick film onto the glass plate after cleaning. Remove any air trapped between the components with a removal aid (squeegee). This will make the non-stick film adhere to the glass plate.
4. Place the VARSEO S cartridge upside down on a clean surface and fit the cleaned sealing ring into the clean groove. Replace the sealing ring, as needed.
5. Position the glass plate with the non-stick film on the cartridge so that the non-stick film is between the cartridge and the glass plate.
6. Place the base plate with the protective ring on the cartridge. Make sure that the handle of the base plate is positioned above the type plate.
7. Use a torque wrench to tighten the bottom plate **crosswise** (illustration) to avoid breaking the glass plate during that process. Additional information can be found under "Tips & Tricks" in the VARSEO S-Service Board (web interface).

NOTE

Slightly grease the inside of the threaded bushings in the bowl with vaseline (small brush). First slightly fix all bolts crosswise and then tighten them one at a time in the same pattern.

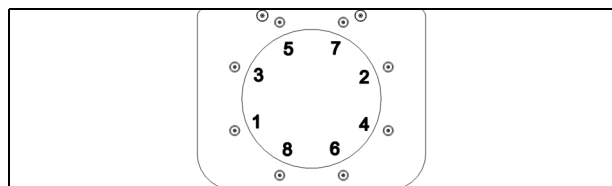

Troubleshooting

Please contact the local retailer if the device is not working properly or if you have any other questions, Have servicing work carried out only by authorized BEGO workshops!

Technical service hotline:
+49 (421) 2028 - (270 ... 274)

Error message	Remedy
Lever not locked in the correct position	<ol style="list-style-type: none"> 1. Release all levers 1 and 2. 2. Check the VARSEO S cartridge for proper position. 3. Lock both levers 1 so that the relevant switch can be safely pressed. 4. Close the locking with lever 2, and latch lever 2.
The VARSEO S cartridge is not clamped.	Close the locking with lever 2, and latch lever 2.
Cover open	Close the cover and press it down until an audible noise indicates that it is latched.

Errors without error message	Remedy
Machine does not move for operation	Please contact the BEGO support quoting the model type and give a detailed description of the fault.
Print job does not stick to the stamp for resin pick up.	<p>The most common cause is remaining fragments in the resin from earlier prints. These will prevent the stamp from resting flush on the non-stick film.</p> <ol style="list-style-type: none"> 1. Completely empty the VARSEO S cartridge with the supplied syringe. 2. Empty the syringe through a fine screen (hole size $\varnothing \sim 0.5$ mm) into a separate container. 3. Clean the entire VARSEO S cartridge with paper towels. 4. Check the non-stick film for signs of damage (replacing the non-stick film → page 40). 5. Fill the resin from the container back into the cleaned VARSEO S cartridge. 6. If the problem continues, contact the BEGO customer service department.
Cover cannot be opened or the cover can only be opened when switched off.	If the device cover is closed and no longer responds to any attempts or the cover cannot be opened, you have the option to open the cover manually. In chapter "Device description (→ page 10) a cap is shown on the right side, where there is an eyelet in an opening. Remove the screw cap with a flat head screwdriver (observe the safety instructions). To open the cover, press the eyelet towards the back of the device.
Print job cannot be started.	Please check the LAN/WLAN connection and the internet connection.

Errors without error message	Remedy
The print job has been exposed for an incorrect amount of time.	If a job was completed with errors or if the object does not stick to the stamp, the exposure time may have been incorrect. In this case do not switch off the printer and do not remove the USB flash-drive from the device. Contact the service department which will check the protocol on the flash-drive.

Signs, labels and stickers

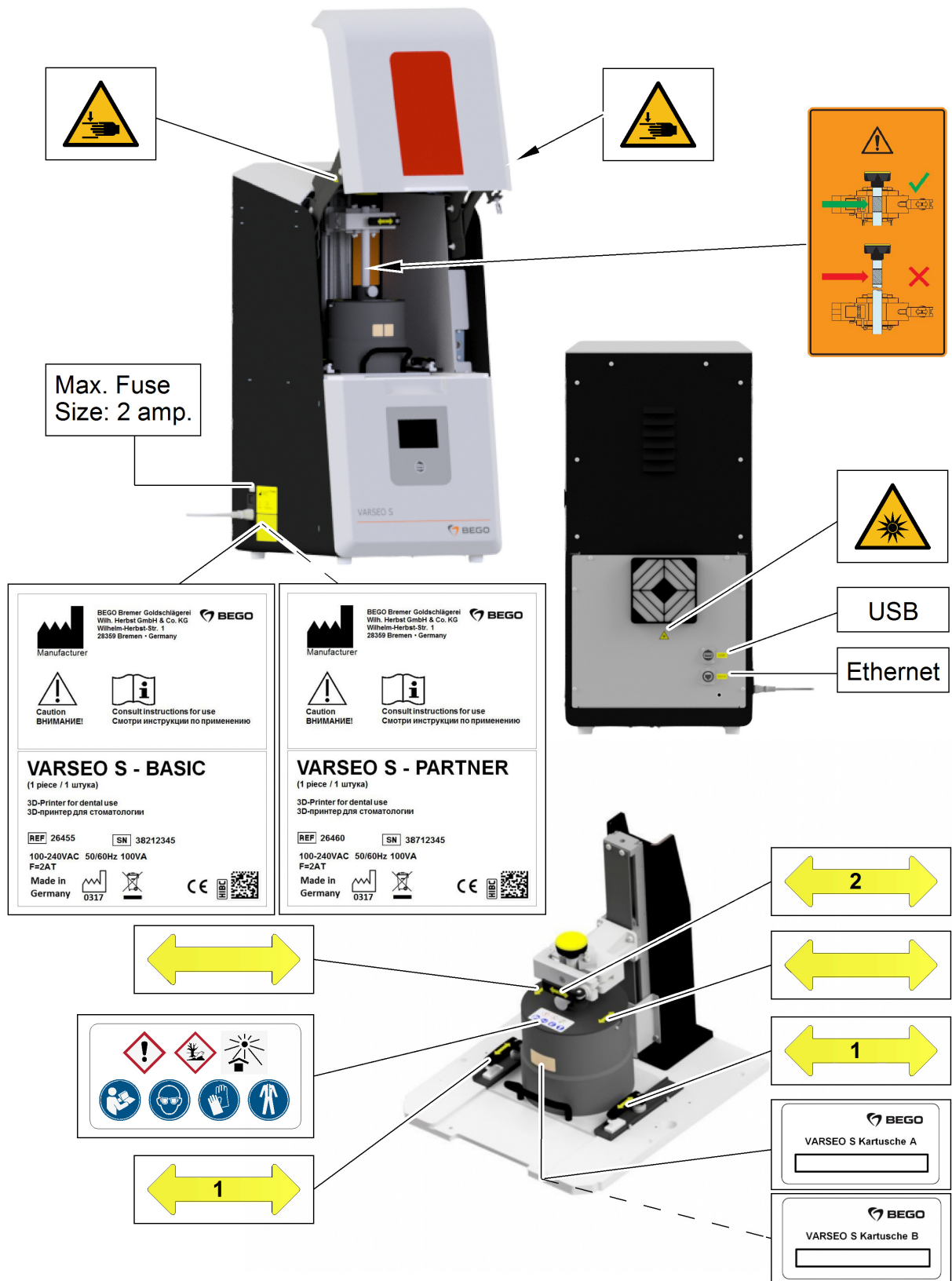

Disposal



Instructions for disposal of the device

(Applicable only within the European Union)

The adjacent symbol on the ID plate of the BEGO device indicates that the device, in accordance with the European directive on waste electrical and electronic equipment, may not be disposed of as normal domestic waste.

As a customer, you contribute to the protection of the environment when you dispose of the device correctly.

Disposal in Germany

BEGO offers you a disposal solution for all BEGO devices sold and put into operation in Germany subsequent to August 13, 2005. Please contact us when it is time to dispose of the device.

Disposal in other countries of the European Union

Please contact the company from which you purchased the BEGO device when it is time to dispose of it. They will provide you with information concerning correct disposal in your region.

Resin waste treatment

Solidified resin can be disposed of with household waste. Do not contaminate standing or flowing waters with resin. Dispose of empty resin containers and contaminated materials in accordance with local regulations. Dispose according to EC Directives on waste and hazardous waste.

Please observe the disposal instructions of the corresponding print resins; further information on handling the product can be found in the material-specific safety data sheets and are also available for download in the BEGO download center under www.bego.com.

DECLARATION OF CONFORMITY

- **Manufacturer:** BEGO Bremer Goldschlägerei
Wilh. Herbst GmbH & Co. KG
Wilhelm-Herbst-Str. 1
28359 Bremen
Germany
T. +49 421 2028-0
F. +49 421 2028-100
www.bego.com
- **Name of products:** Varseo S Basic, Varseo S Partner
- **REF:** 26455, 26460
- **Serial numbers:** 382xxxxx, 387xxxxx
- **Description:** 3D printing system specially developed for dental uses

The products named above conform to the following Directives upon delivery.

- **Directives:** **2006/42/EC of 17 May 2006**
2014/30/EU of 26 February 2014

- **Authorized to compile the technical file:** Alexander Joneit
BEGO Bremer Goldschlägerei
Wilh. Herbst GmbH & Co. KG
Wilhelm-Herbst-Str. 1
28359 Bremen
Germany

Bremen, 15.05.2017

Place, Date

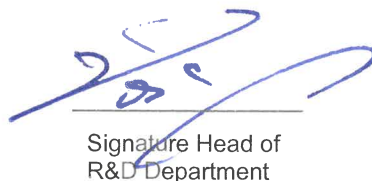

Signature Head of
R&D Department



Signature
Managing Director

- **Česky**
Společnost BEGO Bremer Goldschlägerei Wilh. Herbst GmbH & Co. KG, Bremen - Germany, tímto prohlašuje, že tato **Varseo S** splňuje z ákladní požadavky a další příslušná ustanovení směrnice 2006/42/ES, 2014/30/EU.
- **Dansk**
BEGO Bremer Goldschlägerei Wilh. Herbst GmbH & Co. KG, Bremen - Germany, erklærer herved, at følgende udstyr **Varseo S** overholder de væsentlige krav og øvrige relevante krav i direktiv, 2006/42/EF, 2014/30/EU.
- **Deutsch**
Hiermit erklärt BEGO Bremer Goldschlägerei Wilh. Herbst GmbH & Co. KG, Bremen - Germany, dass sich dieses Gerät **Varseo S** in Übereinstimmung mit den grundlegenden Anforderungen und den anderen relevanten Vorschriften der Richtlinie 2006/42/EG, 2014/30/EU befindet.
- **Eesti keeles**
Käesolevaga kinnitab BEGO Bremer Goldschlägerei Wilh. Herbst GmbH & Co. KG, Bremen - Germany, et see **Varseo S** vastab Euroopa Nõukogu direktiivi 2006/42/EÜ, 2014/30/EL põhinõuetele ja muudele olulistele tingimustele.
- **Ελληνικά**
ΜΕ ΤΗΝ ΠΑΡΟΥΣΑ, BEGO Bremer Goldschlägerei Wilh. Herbst GmbH & Co. KG, Bremen - Germany, ΔΗΛΩΝΕΙ ΟΤΙ ΑΥΤΟ **Varseo S** ΣΥΜΜΟΡΦΩΝΕΤΑΙ ΠΡΟΣ ΤΙΣ ΟΥΣΙΩΔΕΙΣ ΑΠΑΙΤΗΣΕΙΣ ΚΑΙ ΤΙΣ ΛΟΙΠΕΣ ΣΧΕΤΙΚΕΣ ΔΙΑΤΑΞΕΙΣ ΤΗΣ ΟΔΗΓΙΑΣ 2006/42/ΕΚ, 2014/30/ΕΕ.
- **Español**
Por medio de la presente, BEGO Bremer Goldschlägerei Wilh. Herbst GmbH & Co. KG, Bremen - Germany, declara que **Varseo S** cumple con los requisitos esenciales y cualesquiera otras disposiciones aplicables o exigibles de la Directiva, 2006/42/CE, 2014/30/UE.
- **Français**
Par la présente, BEGO Bremer Goldschlägerei Wilh. Herbst GmbH & Co. KG, Bremen - Germany, déclare que les appareils du type **Varseo S** sont conformes aux exigences essentielles et aux autres dispositions pertinentes de la directive 2006/42/CE, 2014/30/UE.
- **Italiano**
Con la presente, BEGO Bremer Goldschlägerei Wilh. Herbst GmbH & Co. KG, Bremen - Germany, dichiara che questo **Varseo S** è conforme ai requisiti essenziali ed alle altre disposizioni pertinenti stabilite dalla direttiva 2006/42/CE, 2014/30/UE.
- **Latviski**
Ar šo BEGO Bremer Goldschlägerei Wilh. Herbst GmbH & Co. KG, Bremen - Germany, apliecina, ka šī **Varseo S** atbilst Direktīvas 2006/42/EK, 2014/30/ES pamatprasībām un citiem atbilstošiem noteikumiem.
- **Lietuviškai**
Šiuo BEGO Bremer Goldschlägerei Wilh. Herbst GmbH & Co. KG, Bremen - Germany, skelbia, kad **Varseo S** tenkina visus svarbiausius 2006/42/EB, 2014/30/ES direktyvos reikalavimus ir kitas svarbias nuostatas.
- **Magyar**
A gyártó BEGO Bremer Goldschlägerei Wilh. Herbst GmbH & Co. KG, Bremen - Germany, kijelenti, hogy ez a **Varseo S** megfelel az 2006/42/EK, 2014/30/EU irányelv alapkövetelményeinek és a kapcsolódó rendelkezéseknek.
- **Malti**
Hawnhekk, BEGO Bremer Goldschlägerei Wilh. Herbst GmbH & Co. KG, Bremen - Germany, jiddikjara li dan **Varseo S** jikkonforma mal-
tīgiġijiet essenzjali u ma provvedimenti oħrajn relevanti li hemm fid-Dirrettiva 2006/42/KE, 2014/30/UE.
- **Nederlands**
Hierbij verklaart, BEGO Bremer Goldschlägerei Wilh. Herbst GmbH & Co. KG, Bremen - Germany, dat **Varseo S** in overeenstemming is met de essentiële eisen en de andere relevante bepalingen van richtlijn 2006/42/EG, 2014/30/EU.
- **Polski**
Niniejszym firma BEGO Bremer Goldschlägerei Wilh. Herbst GmbH & Co. KG, Bremen - Germany, oświadcza, że **Varseo S** spełnia wszystkie istotne wymogi i klauzule zawarte w dokumencie „Directive 2006/42/WE, 2014/30/UE”.
- **Português**
BEGO Bremer Goldschlägerei Wilh. Herbst GmbH & Co. KG, Bremen - Germany, declara que este **Varseo S** está conforme com os requisitos essenciais e outras disposições da Directiva 2006/42/CE, 2014/30/UE.
- **Slovensky**
Výrobca BEGO Bremer Goldschlägerei Wilh. Herbst GmbH & Co. KG, Bremen - Germany, týmto deklaruje, že táto **Varseo S** je v súlade so základnými požiadavkami a ďalšími relevantnými predpismi smernice 2006/42/ES, 2014/30/EÚ.
- **Slovensko**
BEGO Bremer Goldschlägerei Wilh. Herbst GmbH & Co. KG, Bremen - Germany, s tem potrjuje, da je ta **Varseo S** skladen/a z osnovnimi zahtevami in ustreznimi določili Direktive 2006/42/ES, 2014/30/EU.
- **Suomi**
BEGO Bremer Goldschlägerei Wilh. Herbst GmbH & Co. KG, Bremen - Germany, vakuuttaa täten että **Varseo S** tyyppinen laite on direktiivin 2006/42/EY, 2014/30/EU oleellisten vaatimusten ja sitä koskevien direktiivin muiden ehtojen mukainen.
- **Svenska**
Härmed intygas, BEGO Bremer Goldschlägerei Wilh. Herbst GmbH & Co. KG, Bremen - Germany, att denna **Varseo S** står i överensstämmelse med de väsentliga egenskapskrav och övriga relevanta bestämmelser som framgår av direktiv 2006/42/EG, 2014/30/EU.



www.bego.com